

Go Direct[®] Centripetal Force Apparatus

Order Code GDX-CFA (Apparatus Only)

Order Code GDX-CFAF (Apparatus and Sensor)

What's Included

- Apparatus base
- Feet (3)
- Bearing and shaft with 3-step pulley
- Beam with end caps
- Loop attachment for the sensor
- Long thumb screw and 80/20 nut
- Short thumb screw to attach sensor bracket to sensor
- Sensor bracket
- Sliding carriage
- Counterbalance carriage
- 100 gram masses (4)
- 50 gram masses (2)

Note: The Go Direct Force and Acceleration Sensor (order code GDX-FOR) should be used for data collection with this apparatus.

WARNING: Always wear safety glasses when using the Go Direct Centripetal Force Apparatus to prevent injury from the rotating beam.

Assembly Instructions

For complete user manual, visit www.vernier.com/manuals/gdx-cfa

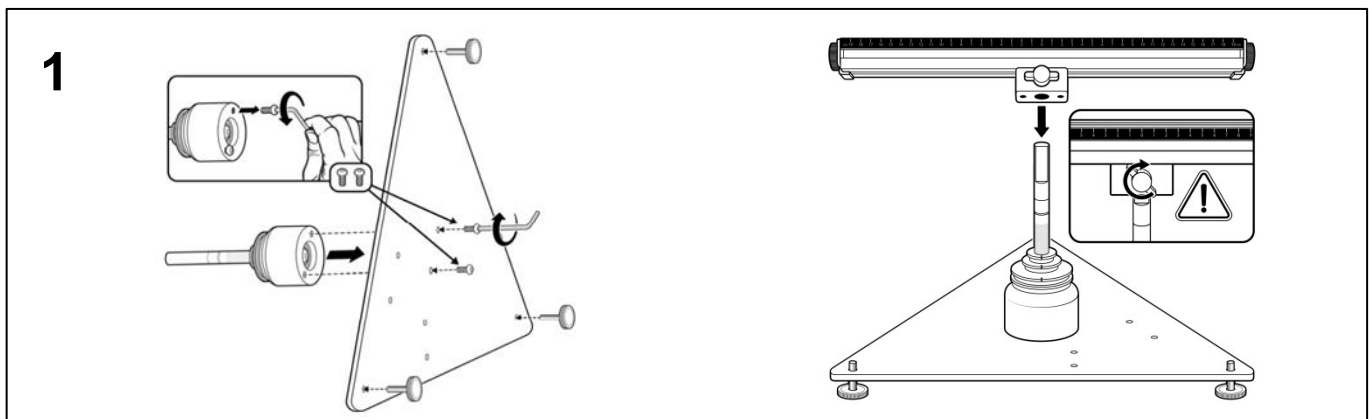
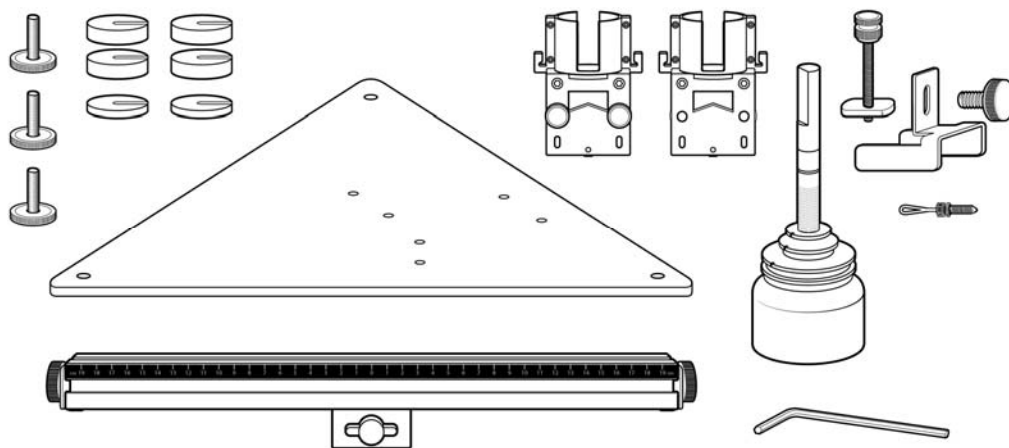

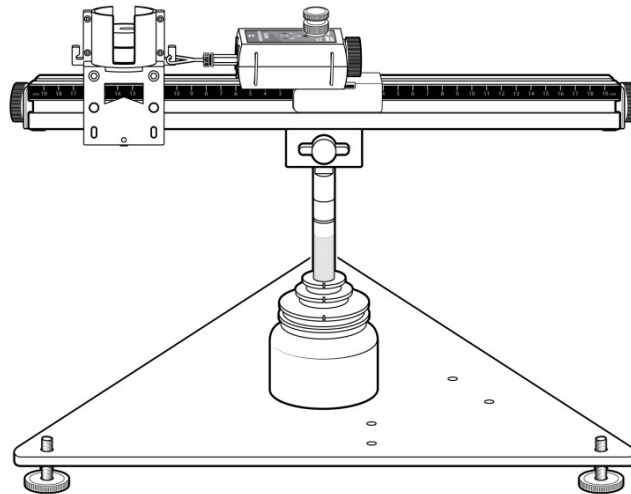
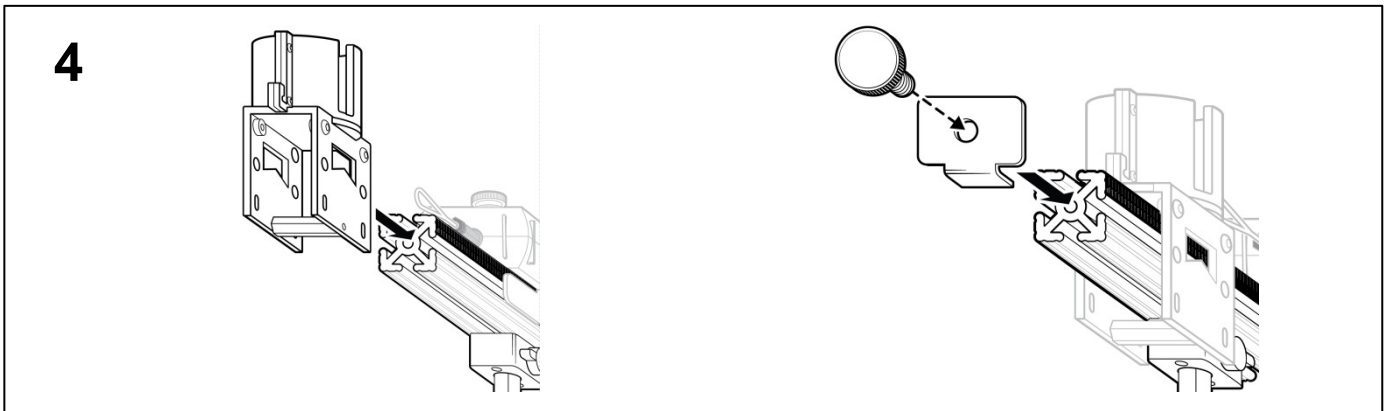
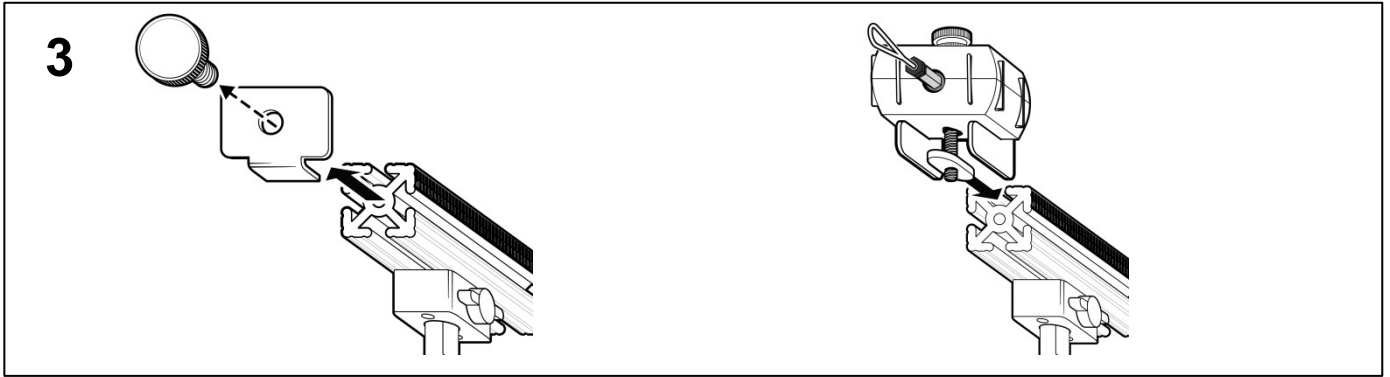
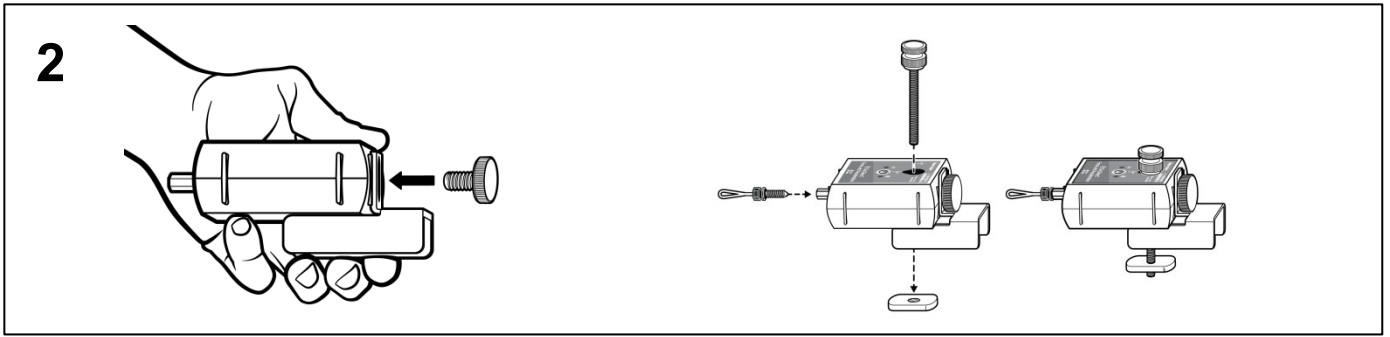

Vernier Science Education

13979 S.W. Millikan Way • Beaverton, OR 97005-2886
Toll Free (888) 837-6437 • (503) 277-2299 • FAX (503) 277-2440
info@vernier.com • www.vernier.com